



US 20160315281A1

(19) **United States**

(12) **Patent Application Publication**
HEO et al.

(10) **Pub. No.: US 2016/0315281 A1**
(43) **Pub. Date: Oct. 27, 2016**

(54) **ORGANIC LIGHT EMITTING DISPLAY DEVICE**

Publication Classification

(71) Applicant: **LG Display Co., Ltd.**, Seoul (KR)

(51) **Int. Cl.**
H01L 51/52 (2006.01)
H01L 51/50 (2006.01)

(72) Inventors: **JoonYoung HEO**, Seoul (KR);
YoungMi KIM, Incheon (KR);
YongMin PARK, Paju-si (KR);
Yoonseob JEONG, Incheon (KR)

(52) **U.S. Cl.**
CPC *H01L 51/5234* (2013.01); *H01L 51/504* (2013.01); *H01L 51/5092* (2013.01); *H01L 51/5072* (2013.01); *H01L 51/5088* (2013.01); *H01L 51/5056* (2013.01); *H01L 2251/308* (2013.01); *H01L 2251/301* (2013.01)

(21) Appl. No.: **14/866,653**

(57) **ABSTRACT**

(22) Filed: **Sep. 25, 2015**

The present invention relates to an organic light emitting display device. An aspect of the present invention provides an organic light emitting display device comprising a first electrode on a substrate, an organic light emitting layer on the substrate, and a second electrode including at least two layers of which a composition of compensation materials is different on the organic light emitting layer.

(30) **Foreign Application Priority Data**

Apr. 23, 2015 (KR) 10-2015-0057471

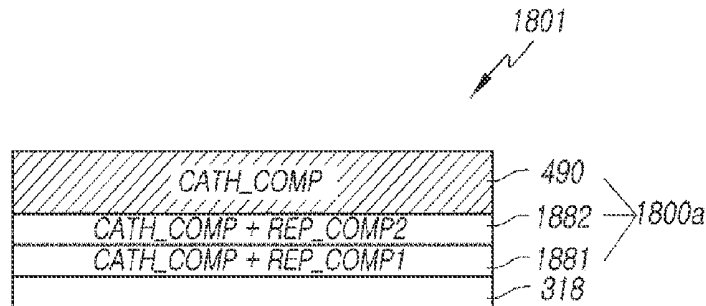

*
*
*

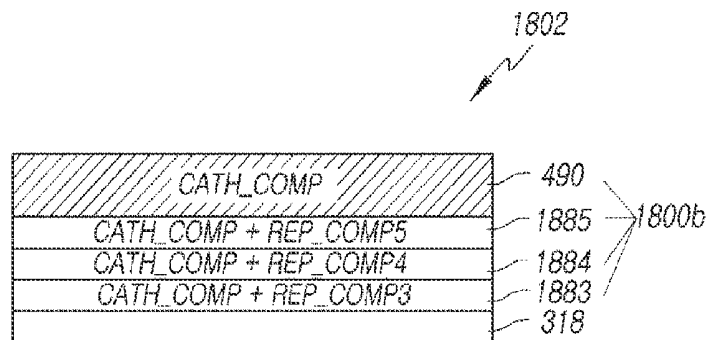

*
*
*

FIG. 1

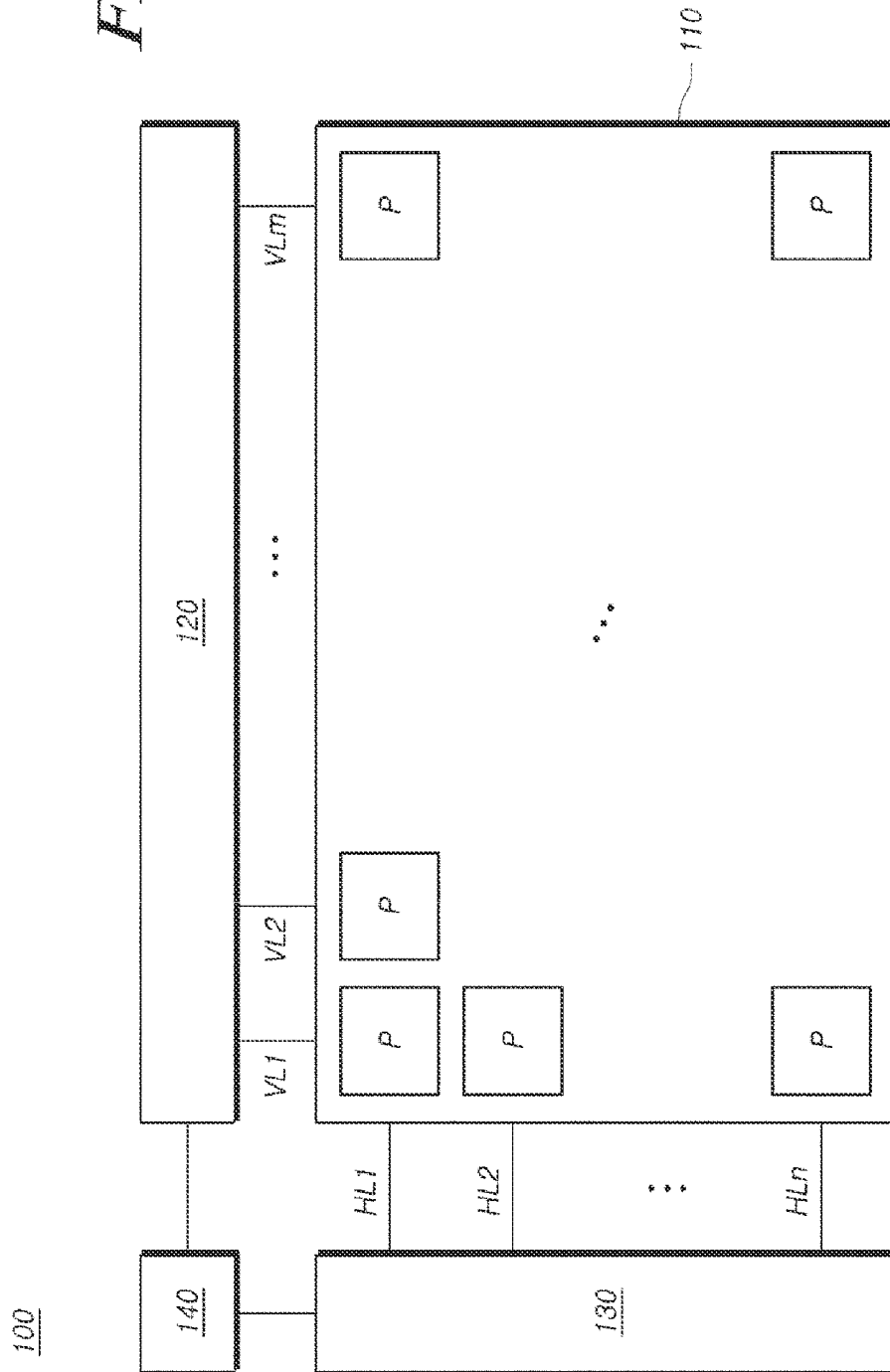

FIG. 2

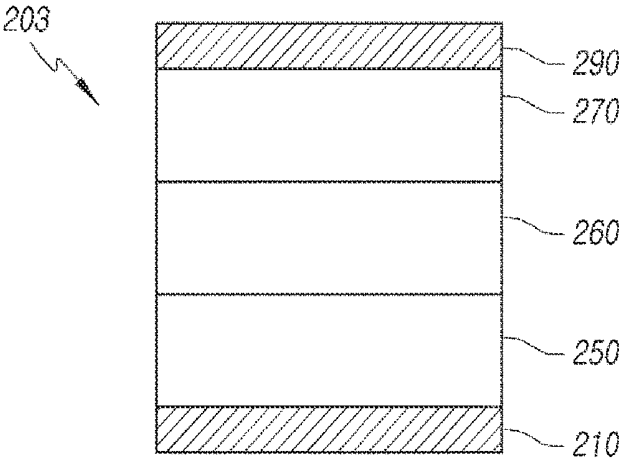
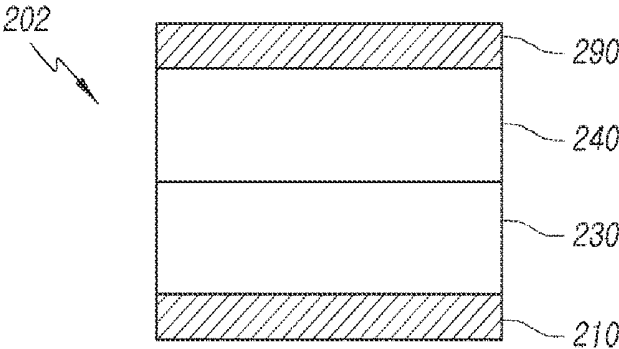
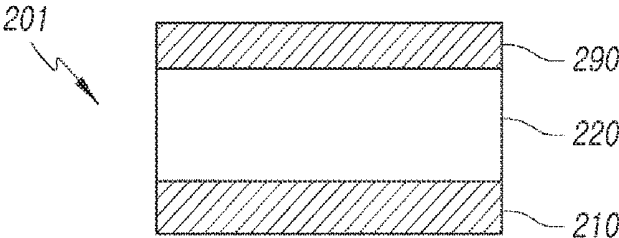

FIG. 3

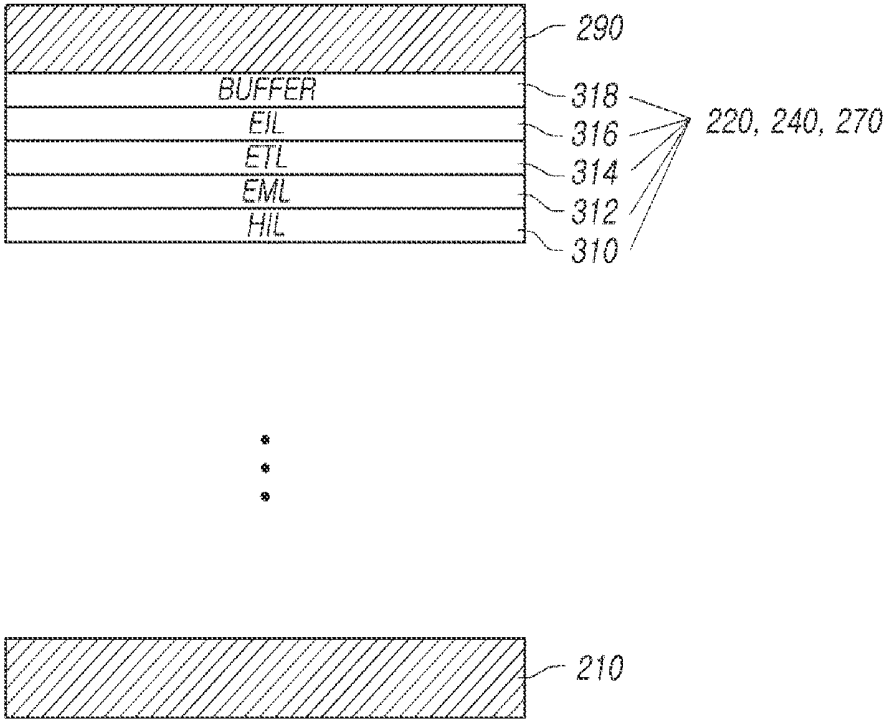

FIG. 4

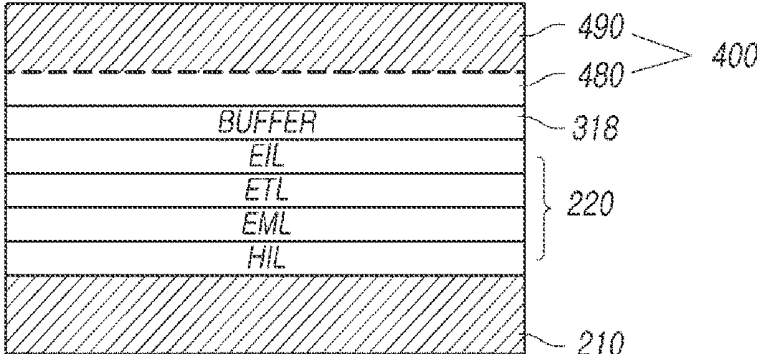

FIG. 5

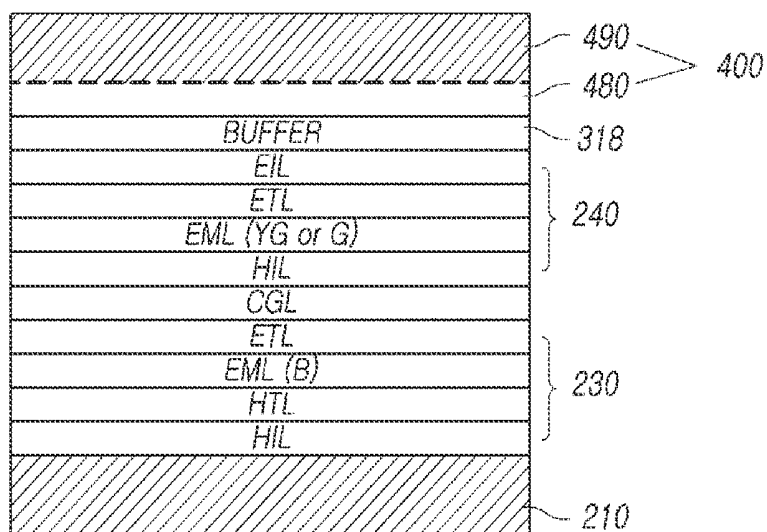

FIG. 6

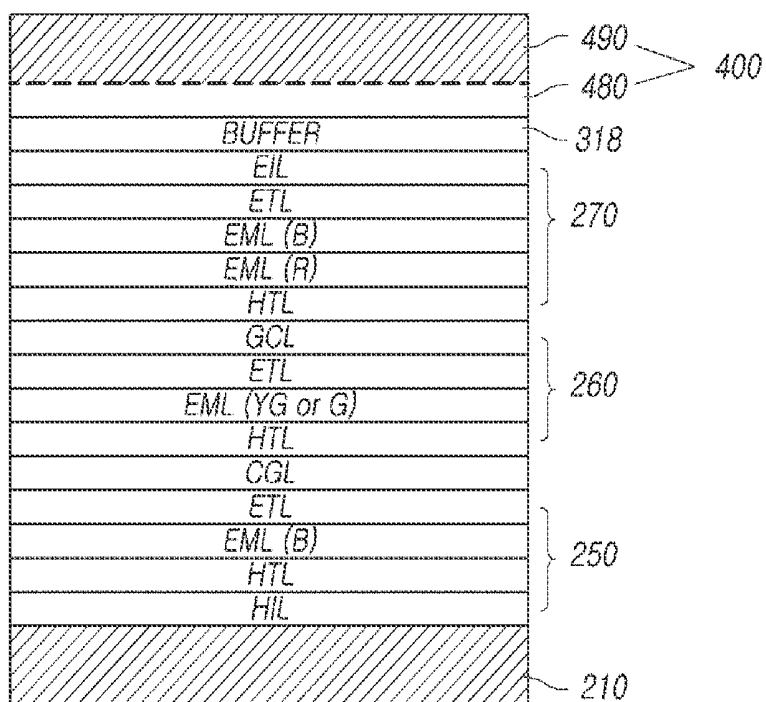

FIG. 7

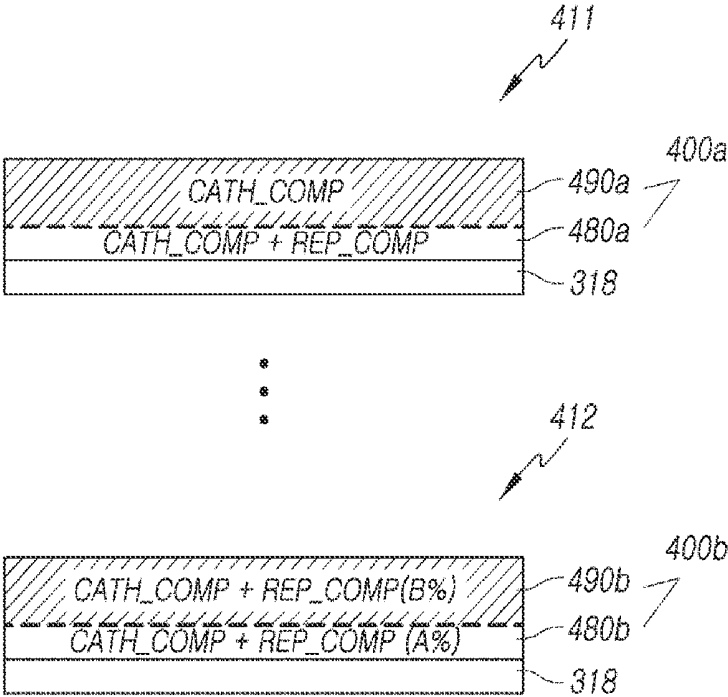

FIG. 8

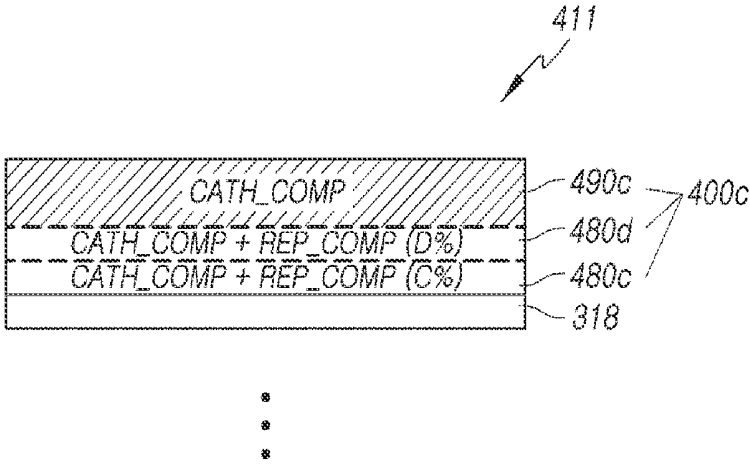

FIG. 9

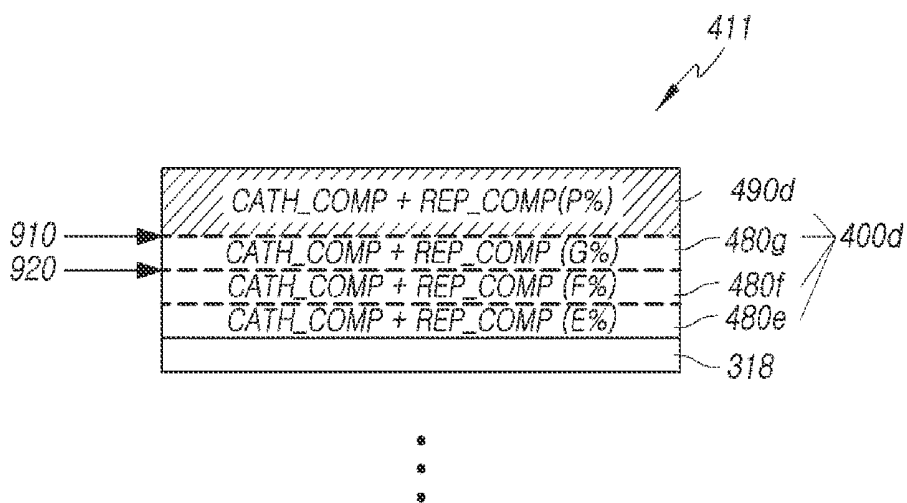

FIG. 10

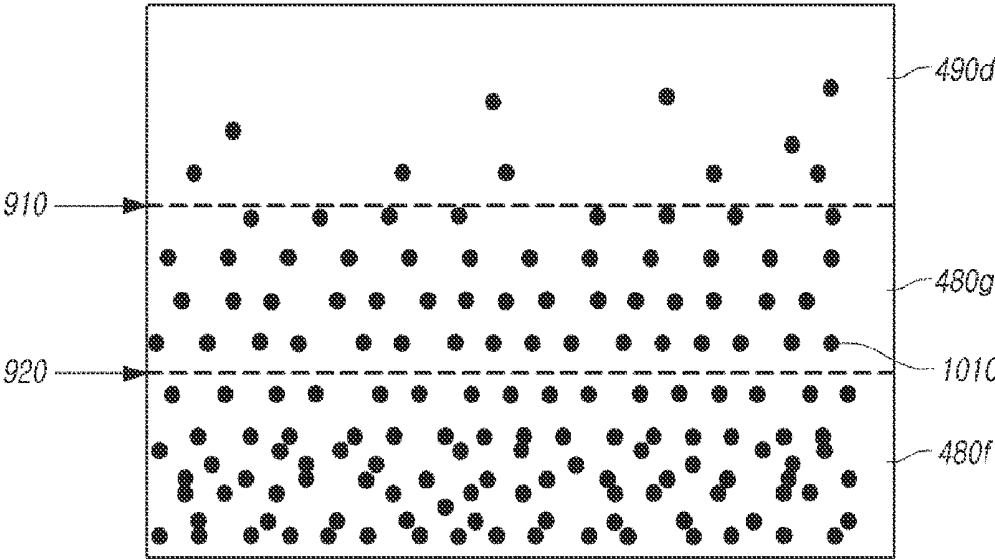

FIG. 11

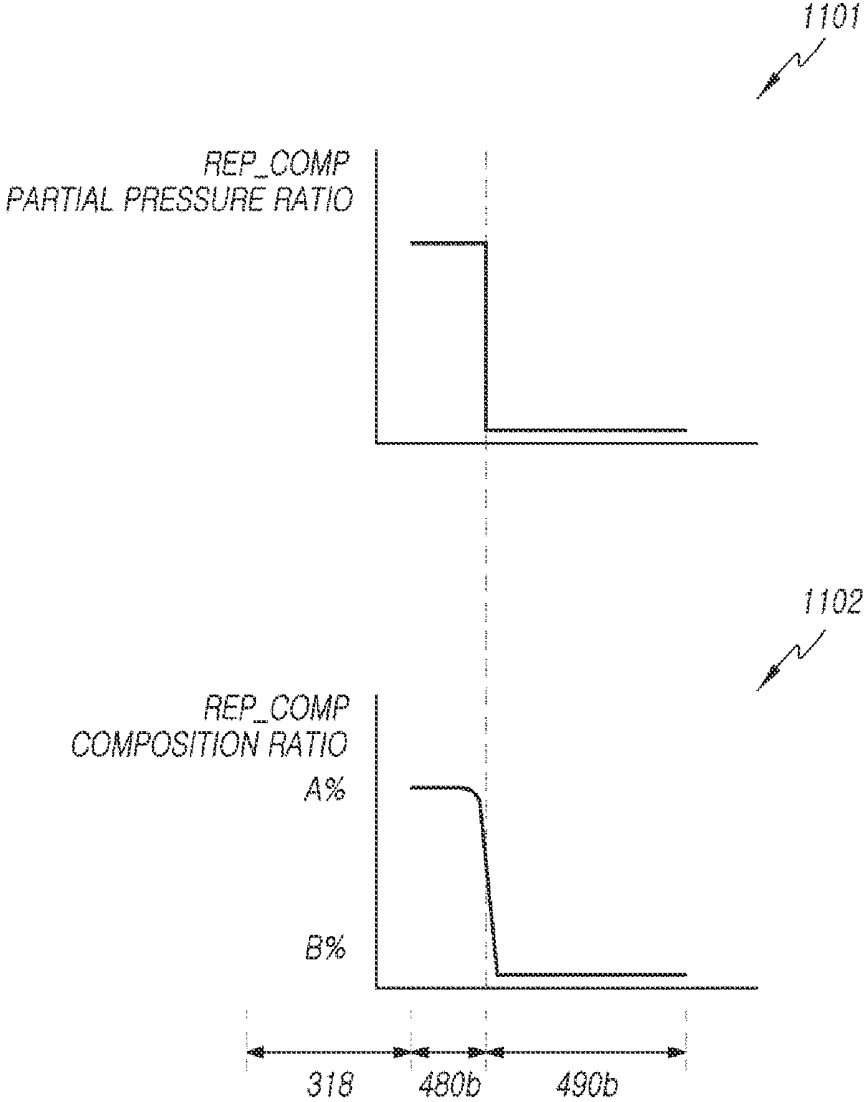

FIG. 12

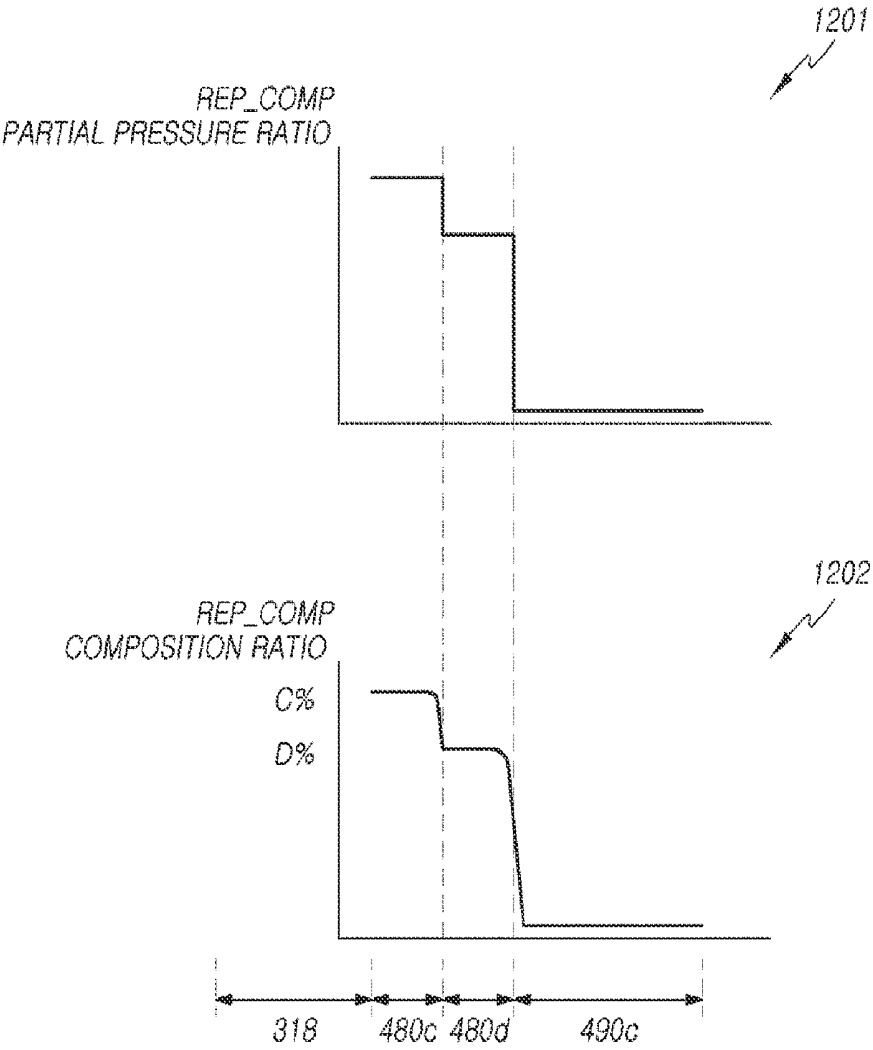

FIG. 13

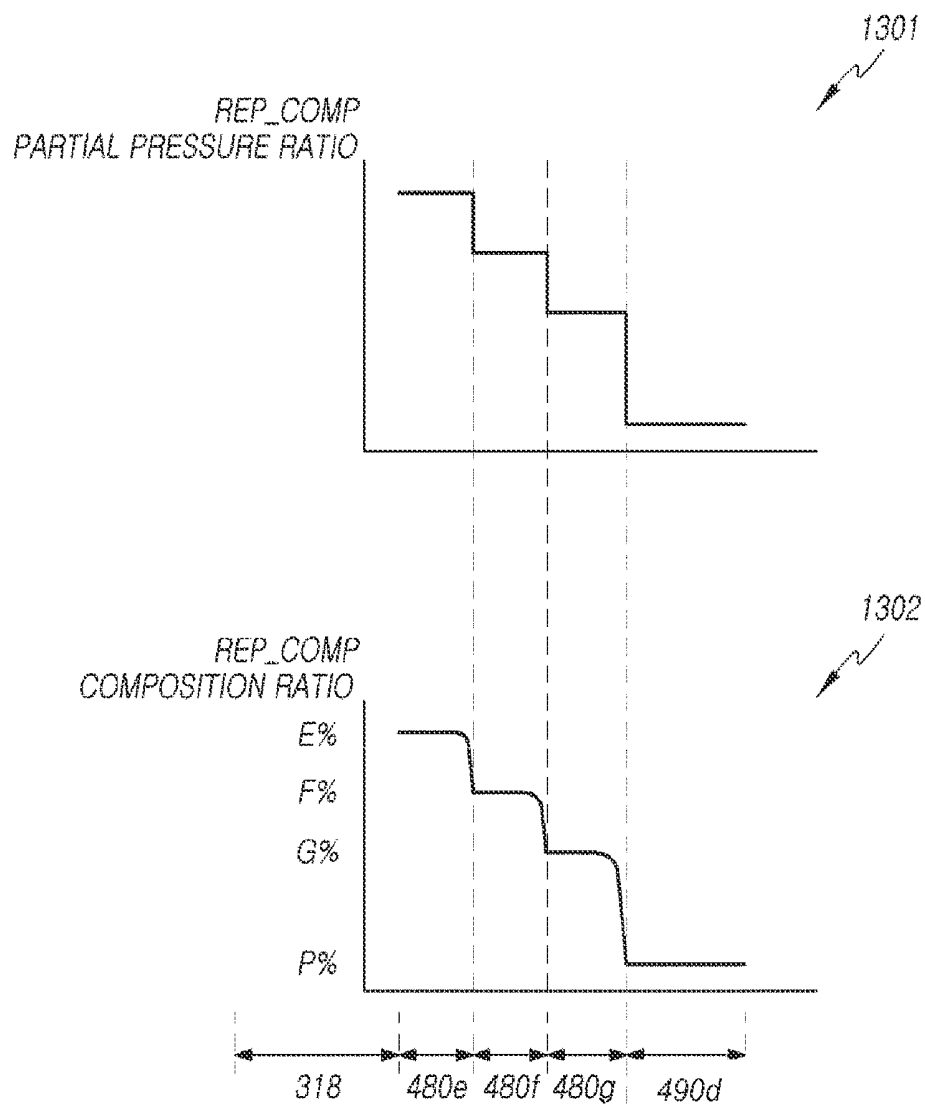

FIG. 14

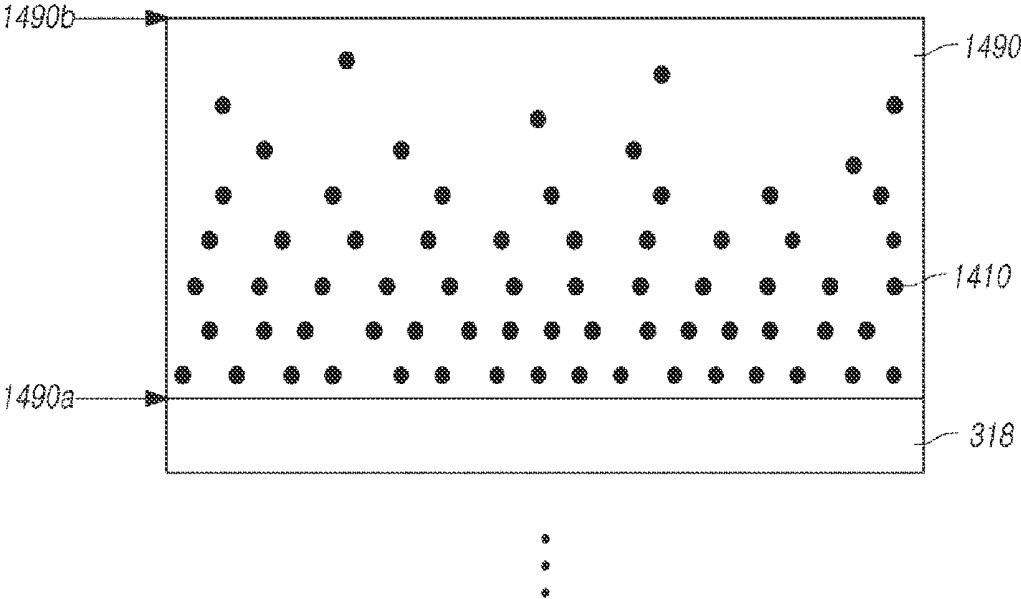

FIG. 15

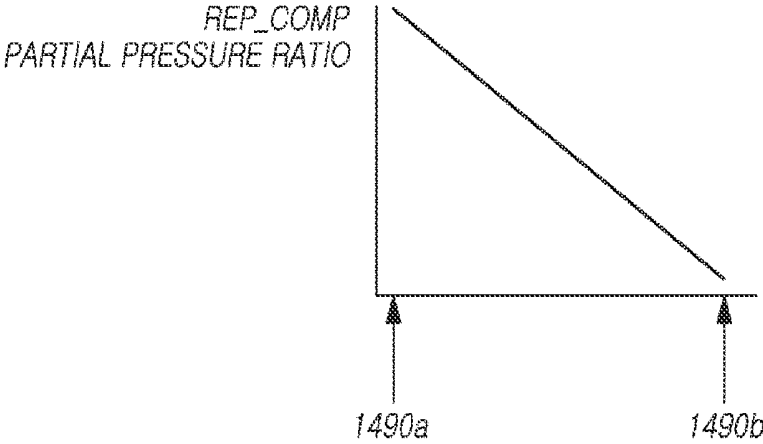

FIG. 16

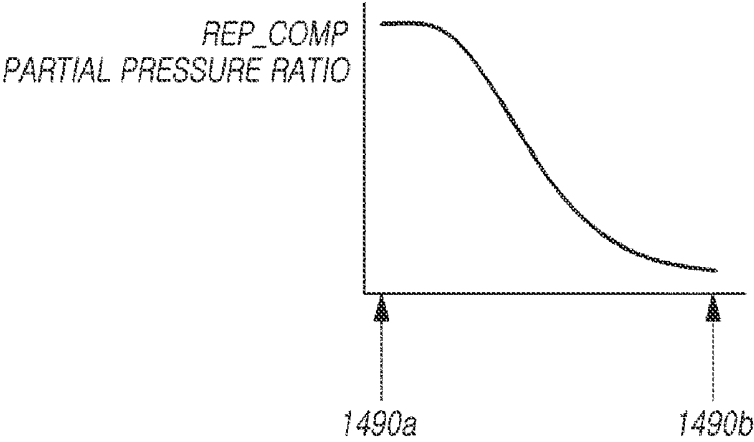

FIG. 17

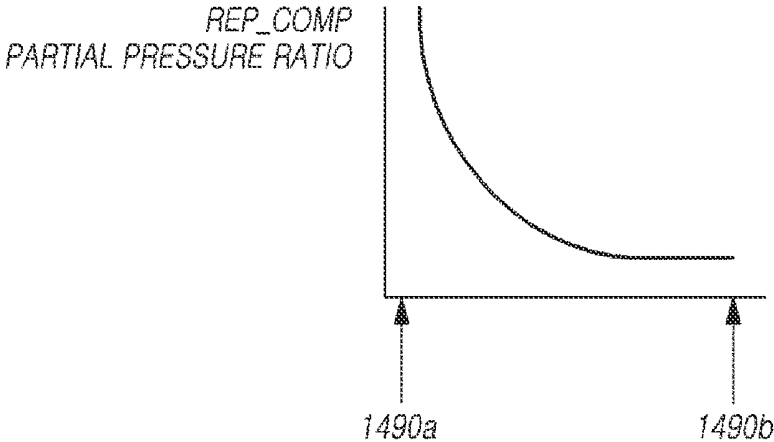

FIG. 18

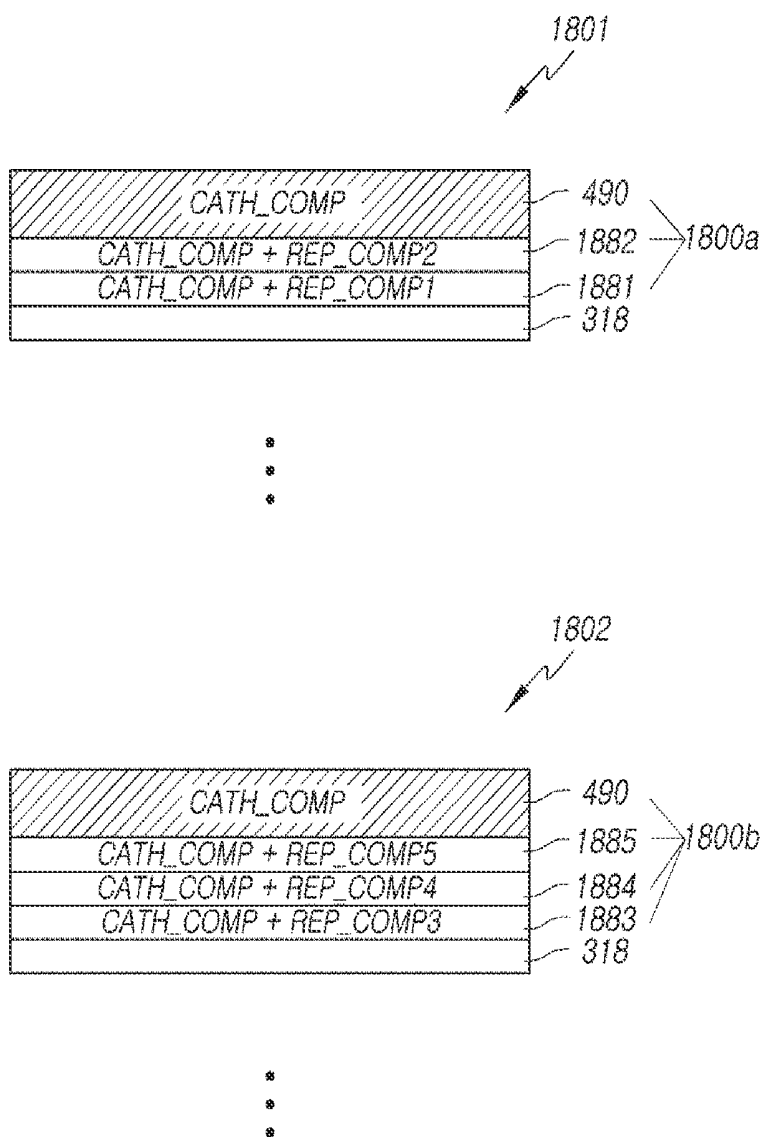
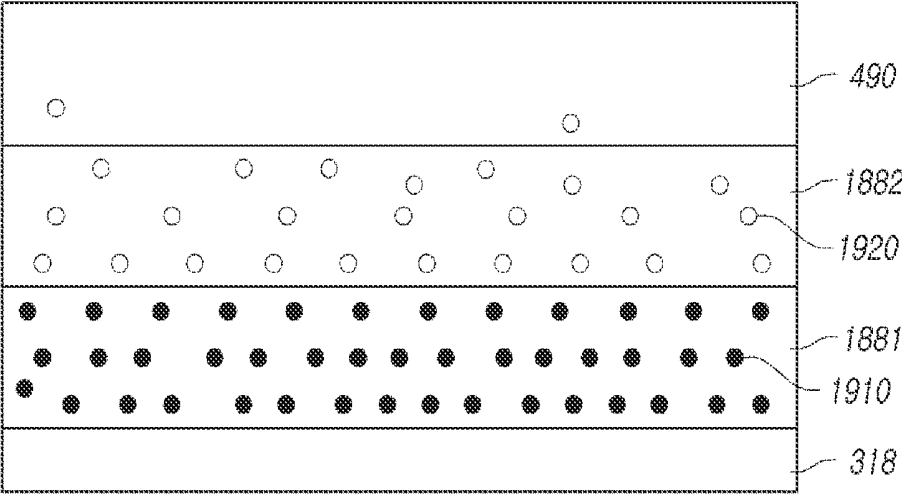

FIG. 19



⋮

FIG. 20

<i>CATH_COMP</i>	<i>REP_COMP</i>
<i>SnO₂</i>	<i>CO₂</i>
	<i>O₂</i>
	<i>O₃</i>
	<i>CH₄</i>
<i>ITO</i>	<i>CH₄O</i>
	<i>COCl₄</i>
	<i>NO</i>
<i>IZO</i>	<i>O₂</i>
	<i>O₃</i>
	<i>N₂</i>
	<i>H₂S</i>

FIG. 21

	THICK.(Å)	
	200	500
O ₂ PARTIAL PRESSURE RATIO(%)	SHEET RESIST (Ω / □)	SHEET RESIST (Ω / □)
9.1	~10 ⁸	~10 ⁸
10.8	~10 ⁹	~10 ⁹
13	~10 ¹⁰	~10 ¹⁰
16.7	~10 ¹¹	~10 ¹¹

FIG. 22

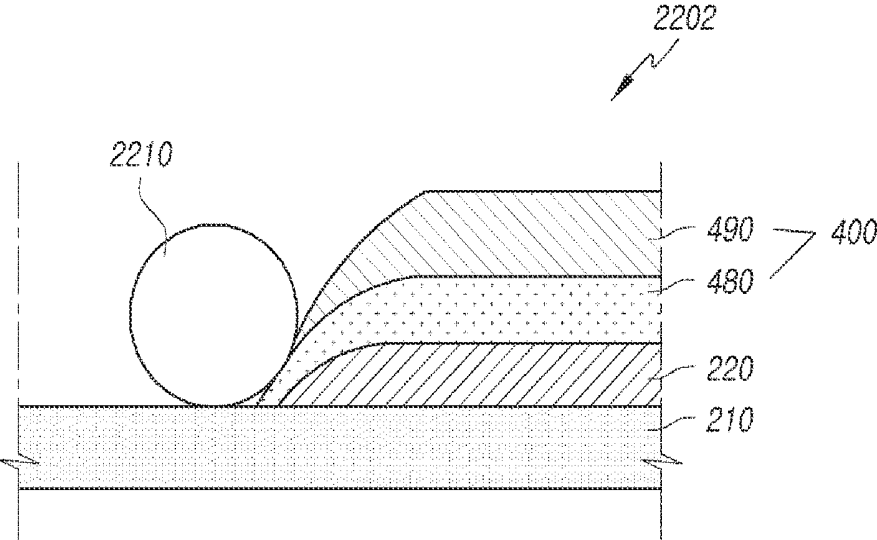
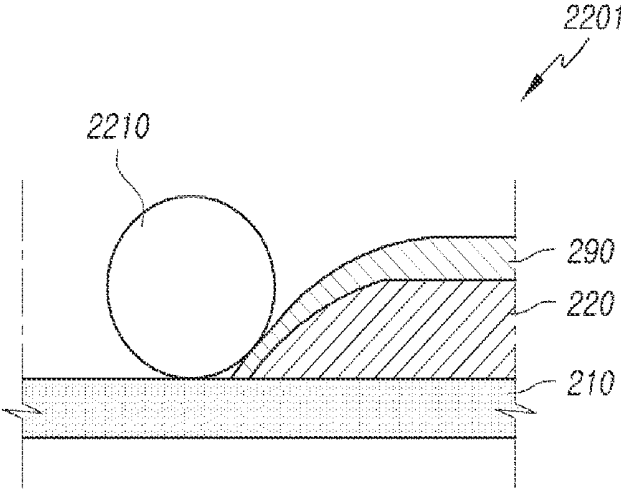

ORGANIC LIGHT EMITTING DISPLAY DEVICE

CROSS-REFERENCE TO RELATED APPLICATION

[0001] This application claims priority from and the benefit under 35 U.S.C. §119(a) of Korean Patent Application No. 10-2015-0057471, filed on Apr. 23, 2015, which is hereby incorporated by reference for all purposes as if fully set forth herein.

BACKGROUND OF THE INVENTION

[0002] 1. Field of the invention

[0003] The present invention relates to an organic light emitting display device that includes a foreign body compensation layer.

[0004] 2. Description of the Prior Art

[0005] With the development of an information-oriented society, the demands for various display devices for displaying images are increasing. Recently, various display devices, such as an LCD (Liquid Crystal Display), a PDP (Plasma Display Panel), an OLED (Organic Light Emitting Display Device), or an organic electro-luminescence display device, have been utilized. The various display devices include display panels corresponding thereto.

[0006] In the display panel, a thin film transistor is formed in each pixel area, and a specific pixel area is controlled through the current flow of the thin film transistor. The thin film transistor is comprised of a gate and a source/drain electrode.

[0007] The organic light emitting display includes a light-emitting layer that is formed between two different electrodes. When an electron created by one electrode and a hole created by the other electrode are injected into the light-emitting layer, the injected electron and the hole combine with each other to create an exciton. Then, the created exciton emits light while it transitions from the excited state to the ground state to thereby display images.

[0008] Meanwhile, a minute particle may enter into a display device during the process of manufacturing an organic light emitting display device, and such a particle is referred to as a foreign body. When the foreign body exists between electrodes, which should maintain an insulated state, a short may be generated between the electrodes, and the short may damage a specific pixel. Thus, in order to prevent a short due to a foreign body, a thick material may be spread. However, spreading the thick material may reduce the visibility of the organic light emitting display device. In addition, since an additional process is required, the cost may increase or the process efficiency may be reduced. Thus, a configuration capable of preventing a foreign body while maintaining the efficiency of the process, is necessary.

SUMMARY OF THE INVENTION

[0009] In this background, an aspect of the present invention is to prevent a defect due to a foreign body in an organic light emitting display device or a display panel.

[0010] Another aspect of the present invention is to include a layer compensating a foreign body, which is to prevent a short due to the foreign body being between a cathode and an anode when the cathode is formed thinly in

order to increase the transmittance of the cathode in a top emission structure, under the cathode.

[0011] Another aspect of the present invention is to reduce the generation rate of a dark spot due to a short between a cathode and an anode, and thus increase the efficiency of a display panel.

[0012] According to an aspect of the present invention, an organic light emitting display device comprises a first electrode on a substrate, an organic light emitting layer on the substrate, and a second electrode including at least two layers, of which a composition of compensation materials is different on the organic light emitting layer.

[0013] According to another aspect of the present invention, an organic light emitting display device is provided such that a second electrode comprises a compensation layer and an electrode layer sequentially positioned from an organic light emitting layer, and a composition ratio of a compensation material included in a compensation layer is larger than that of a compensation material of a compensation material included in a second layer.

[0014] According to an aspect of the present invention, an organic light emitting device comprises a substrate, a first electrode on the substrate, an organic light emitting layer on the first electrode, and a second electrode of which compositions of a compensation material are different at a first interface close to the organic light emitting layer and at a second interface opposite to the first interface.

[0015] According to another aspect of the present invention, an organic light emitting device is provided such that the composition ratio of the compensation material in a second electrode is the highest at the first interface and the composition ratio of the compensation material in the second electrode is the lowest at the second interface.

[0016] As described above, according to the present invention, an organic light emitting display device, in which a compensation layer for compensating a foreign body is included, may be implemented. In addition, a compensation layer may be deposited by differentiating the composition ratio or the composition of a gas including a compensation material that forms the compensation layer during the process of forming a second electrode, such as a cathode.

[0017] According to the present invention, a short between a cathode and an anode caused by a foreign body may be prevented by a second electrode including a compensation layer and an electrode layer. In addition, a compensation layer securing a transmittance of a second electrode is formed and thus the light efficiency of an organic light emitting display device may increase.

[0018] According to the present invention, during the forming of a layer for compensating a foreign body, since only a partial pressure ratio of a compensation material, such as oxygen and ozone, may be controlled during the forming of a second electrode, such as a cathode, without an additional device, the process efficiency may be increased and the process cost may be reduced.

BRIEF DESCRIPTION OF THE DRAWINGS

[0019] The above and other objects, features, and advantages of the present invention will be more apparent from the following detailed description taken in conjunction with the accompanying drawings, in which:

[0020] FIG. 1 is a schematic view illustrating a display device according to an embodiment of the present invention;

[0021] FIG. 2 is a view illustrating the structure of an organic light emitting layer, a first electrode and a second electrode, to which the present invention may be applied;

[0022] FIG. 3 is a view illustrating a configuration below the second electrode in a configuration of FIG. 2 in more detail;

[0023] FIGS. 4 to 6 are views illustrating a cross-section of a display panel in which a second electrode including a foreign body compensation layer, according to an embodiment of the present invention, is positioned;

[0024] FIGS. 7 to 10 are cross-sectional views of a display panel according to the first embodiment of the present invention;

[0025] FIGS. 11 to 13 are views illustrating a partial pressure ratio of a compensation material for forming a second electrode shown in FIGS. 7 to 9 and a composition ratio of the compensation material in the second electrode due to the partial pressure ratio;

[0026] FIG. 14 is a cross-sectional view of a display panel according to a second embodiment of the present invention;

[0027] FIGS. 15 to 17 are graphs illustrating a composition ratio of an Rep_Comp in a configuration of FIG. 14;

[0028] FIG. 18 is a cross-sectional view of a display panel according to a third embodiment of the present invention;

[0029] FIG. 19 is a view illustrating the distribution of a compensation material of a second electrode and a compensation layer including two types of materials according to the third embodiment of the present invention;

[0030] FIG. 20 is a chart illustrating a relation between a Cath_Comp, which is a material forming the second electrode, and an Rep_Comp, which is a material sputtered to form the compensation layer;

[0031] FIG. 21 is a chart illustrating an increase of a sheet resistance according to a partial pressure ratio of the Rep_Comp, according to an embodiment of the present invention; and.

[0032] FIG. 22 is a view illustrating a comparison between the existing panel and a panel in which the foreign body compensation layer proposed in the present invention is included.

DETAILED DESCRIPTION OF THE EXEMPLARY EMBODIMENTS

[0033] Hereinafter, embodiments of the present invention will be described with reference to the accompanying drawings. In designating elements of the drawings by reference numerals, the same elements will be designated by the same reference numerals although they are shown in different drawings. Further, in the following description of the present invention, a detailed description of known functions and configurations incorporated herein will be omitted when it may make the subject matter of the present invention rather unclear.

[0034] In addition, terms, such as first, second, A, B, (a), (b) or the like may be used herein when describing components of the present invention. Each of these terminologies is not used to define an essence, order or sequence of a corresponding component but used merely to distinguish the corresponding component from other component(s). In the case that it is described that a certain structural element "is connected to", "is coupled to", or "is in contact with" another structural element, it should be interpreted that another structural element may "be connected to", "be coupled to", or "be in contact with" the structural elements

as well as that the certain structural element is directly connected to or is in direct contact with another structural element.

[0035] FIG. 1 is a schematic view illustrating a display device according an embodiment of the present invention.

[0036] Referring to FIG. 1, the display device 100 according to embodiments includes a display panel 110 in which a plurality of first lines VL1 to VLm are formed in a first direction (for example, a vertical direction) and a plurality of second lines HL1 to HLn are formed in a second direction (for example, a horizontal direction), a first driving unit 120 for supplying a first signal to the plurality of first lines VL1 to VLm, a second driving unit 130 for supplying a second signal to the plurality of second lines HL1 to HLn, and a timing controller 140 for controlling the first driving unit 120 and the second driving unit 130.

[0037] A plurality of pixels P are defined in the display panel 110 as the plurality of first lines VL1 to VLm formed in the first direction (for example, a vertical direction) and the plurality of second lines HL1 to HLn formed in the second direction (for example, a horizontal direction) cross each other.

[0038] Each of the above-mentioned first driving unit 120 and second driving unit 130 may include at least one driving integrated circuit outputting a signal for an image display.

[0039] The plurality of first lines VL1 to VLm formed in the display panel 110 in the first direction may be, for example, data lines formed in the vertical direction (first direction), for transferring a data voltage (first signal) to vertical columns of pixels, and the first driving unit 120 may be a data driving unit for supplying a data voltage to the data lines.

[0040] In addition, the plurality of second lines HL1 to HLn formed in the display panel 110 in the second direction may be gate lines formed in the horizontal direction (second direction), for transferring a scan signal (first signal) to horizontal rows of pixels, and the second driving unit 130 may be a gate driving unit for supplying a scan signal to the gate lines.

[0041] In addition, a pad part is configured in a display panel 110 in order to access the first driving unit 120 and the second driving unit 130. The pad part transfers the first signal to the display panel 110 when the first driving unit 120 provides the first signal to the plurality of first lines VL1 to VLm. In the same manner, the pad part transfers the second signal to the display panel 110 when the second driving unit 130 provides the second signal to the plurality of second lines HL1 to HLn.

[0042] Each pixel includes at least one subpixel. The subpixel means a unit in which one type of a specific color filter may be formed, or a unit in which a color filter is not formed and an organic light emitting device emits a specific color. A color defined in the subpixel may include a red, a green and a blue, and may selectively include a white color. However, the present invention is not limited thereto. Since each subpixel includes an additional thin film transistor and an electrode connected to the thin film transistor, hereinafter the subpixel forming a pixel is referred to as one pixel area.

[0043] An electrode connected to a thin film transistor controlling a light emission of each pixel area in a display panel is referred to as a first electrode. An electrode disposed on a front surface of the display panel or disposed so as to include two or more pixel areas is referred to as a second electrode. When the first electrode is an anode electrode, the

second electrode is a cathode electrode, and the inverse case is possible. Hereinafter, the present specification is described based on an anode electrode as an embodiment of the first electrode and a cathode electrode as an embodiment of the second electrode, but the present invention is not limited thereto.

[0044] Meanwhile, an organic light emitting display device includes a top emission, a bottom emission, a dual emission and the like. Although any emission type is selected, an area where a process should be progressed becomes wider in a large area display panel of which an area of a display panel increases, and thus the possibility of the entrance of a foreign body is increased. Specially, when the foreign body enters into an area between the first electrode and the second electrode, where a short should not be generated in a process, a short may be generated, and thus a corresponding pixel area may be operated as a dark spot.

[0045] FIG. 2 is a view illustrating the structure of an organic light emitting layer, a first electrode and a second electrode, to which the present invention may be applied. The organic light emitting layer is positioned between the first electrode 210 and the second electrode 290. The display panel may have one organic light emitting layer as shown by a reference numeral 201, may have two organic light emitting layers as shown by a reference numeral 202, and may have three organic light emitting layers as shown by a reference numeral 203.

[0046] In the case of the reference numeral 201, an organic light emitting layer 220 emits white light.

[0047] In the case of the reference numeral 202, a first light emitting layer 230 may emit blue light, and a second organic light emitting layer 240 may emit any of green light or yellow-green light.

[0048] In the case of the reference numeral 203, a first light emitting layer 250 may emit blue light, a second organic light emitting layer 260 may emit any of green light or yellow-green light, and a third light emitting layer 270 may emit both of red light and blue light.

[0049] A specific color dopant may be doped in a configuration of FIG. 2 in order to emit a specific color.

[0050] Compositions of various colors of the light emitting layers in the reference numerals 201, 202 and 203 may be selected variously according to an embodiment of the present invention, and the present invention is not limited thereto.

[0051] In the configuration of FIG. 2, the first electrode 210 may be Indium Tin Oxide (ITO), Indium Zinc Oxide (IZO), IGZO, SnO₂, ZnO and the like as a transparent conductive material of which the conductivity and work function are high. In addition, when the first electrode 210 includes a metal of which a work function is low, the first electrode 210 may be Al, Ag, Mg, Li, Ca and the like, but is not limited thereto. The second electrode 290 may be the above-mentioned ITO, IZO, IGZO, SnO₂, ZnO and the like which are transparent conductive materials having a high work function. In addition, when the second electrode 290 includes a metal of which a work function is low, the second electrode 290 may be Al, Ag, Mg, Li, Ca and the like, but is not limited thereto.

[0052] FIG. 3 is a view illustrating a configuration below the second electrode in the configuration of FIG. 2 in more detail.

[0053] The above-mentioned organic light emitting layer may be divided into an Emission Layer (EML), an Electron

Injection Layer (EIL), an Electron Transport Layer (ETL), an Hole Transport Layer (HTL), a Hole Injection Layer (HIL) and the like. In addition, when two or more EMLs are included in the organic light emitting layer, a Charge Generation Layer (CGL) may be positioned, and the CGL plays a role of controlling a charge between two upper and lower organic light emitting layers to balance.

[0054] Meanwhile, the configuration of the light emitting layers 220, 240 and 270 below the second electrode includes a buffer 318, the EIL 316, the ETL 314, a specific color of EML 312 and the HIL 310.

[0055] In FIGS. 2 and 3, when a foreign body enters into an area between the first electrode 210 and the second electrode 290 and thus a short is generated between the first electrode 210 and the second electrode 290 due to the foreign body, a corresponding pixel does not light. In order to prevent this, when the area between the first electrode 210 and the second electrode 290 is formed thickly, for example a thickness of the buffer layer 318 is increased, a problem arises in which light efficiency is reduced.

[0056] Hereinafter, in the present specification, an organic light emitting layer including a compensation layer compensating a foreign body below the second electrode is described. Especially, the compensation layer may make the composition ratio or the composition amount of a gas included in a compensation material that forms the compensation layer different during the process of forming the second electrode such that an additional process is not required.

[0057] A composition component may be different according to the distance from the second electrode, according to an embodiment of the present invention to the buffer layer. More specifically, the second electrode may be divided into an electrode layer and a compensation layer. As another embodiment, the second electrode may be formed such that the composition material of the second electrode at an interface adjacent to the buffer layer is different from the composition material of the second electrode at an interface far from the buffer layer. To this end, the compensation material is included in the present invention, a high resistance area is formed in a lower portion of the second electrode, which is an area close to the buffer layer, and a low resistance area is formed in an upper portion of the second area, which is an area far from the buffer layer. Therefore, the high resistance area functions as the compensation layer compensating the foreign body, and the low resistance area functions as the electrode layer receiving a base power.

[0058] FIGS. 4 to 6 are views illustrating a cross-section of a display panel in which a second electrode including a foreign body compensation layer, according to an embodiment of the present invention, is positioned. A configuration of FIG. 4 may be applied to the reference numeral 201 of FIG. 2. A configuration of FIG. 5 may be applied to the reference numeral 202 of FIG. 2. A configuration of FIG. 6 may be applied to the reference numeral 203 of FIG. 2.

[0059] In FIGS. 4 to 6, each layer is segmentalized and shown. The above-mentioned organic light emitting layer may include the ETL, the EML, and HTL, and may selectively include the EIL and the HIL according to the position of the first electrode 210 and a second electrode 490. In addition, the CGL may be located between the organic light emitting layers.

[0060] In FIGS. 4 to 6, the cases in which the number of the organic light emitting layers is one, two, or three are shown as an embodiment, but the present invention is not limited thereto. In FIG. 5, a first emitting layer 240 may emit yellow-green light or green light, the second light emitting layer 230 may emit blue light, and may emit white light by combining these colors. In even FIG. 6, the white light may be emitted by combining colors of three types of light emitting layers 250, 260, and 270. In the configuration of FIGS. 4 to 6, the second electrode is divided into two layers, including the compensation layer. In addition, the second electrode includes the compensation layer that prevents a cathode-anode short due to a foreign body even in a case in which the second electrode should be spread thinly. In addition, in order to increase the light emission efficiency of the white light, a compensation layer securing a transmittance of the second electrode is formed in the present invention to increase a light efficiency, instead of a compensation layer, of which a transmittance is low, is formed below the second electrode.

[0061] In FIGS. 4 to 6, a second electrode 400 is divided into an electrode layer 490 and a compensation layer 480. The two above-mentioned layers may be differentiated according to a composition ratio of a compensation material forming the compensation layer. Thus, an interface between the two layers may not be clear. That is, in the second electrode 400, the electrode layer 490 and the compensation layer 480 may not be differentiated by an accurate interface. However, the second electrode 400 may include a high resistance area and a low resistance area which are two areas, in which the high resistance area, where the distribution of a compensation material is high, may function as the compensation layer 480 compensating the foreign body, and the low resistance area, where the distribution of the compensation material is low, may function as the electrode layer 490 receiving power.

[0062] In FIGS. 4 to 6, the compensation layer 480 may be formed by controlling an injection amount of a compensation gas during the process of forming the second electrode 400. For example, the compensation material which forms the compensation layer 480 while sputtering a material forming the second electrode 400 is plentifully injected initially, and then the injection amount may be reduced gradually. Accordingly, the compensation layer 480 of the high resistance area is formed in the area adjacent to the buffer layer 318. In addition, after the injection amount of the compensation material is reduced, the electrode layer 490 may be formed on the compensation layer 480. The above-mentioned compensation material may be combined with an electrode material forming the electrode layer 490. In addition, the above-mentioned compensation material may be a material for increasing the resistance of the electrode layer 490, as an embodiment.

[0063] The second electrode 400 may include the electrode material and the compensation material, which are two types of materials. Of course, each material may be a compound of another material. In the second electrode 400, the ratio between the electrode material and the compensation material in the compensation layer or the high resistance area 480 is different from the ratio between the electrode material and the compensation material in the electrode layer or the low resistance area 490.

[0064] Hereinafter, for the convenience of description, the electrode material is indicated as "Cath_Comp", and the

compensation material is indicated as "Rep_Comp". A configuration of "Rep_Comp" forming the compensation layer 480 and the electrode layer 490 may increase as the configuration of "Rep_Comp" is close to an upper interface of the second electrode 400. Alternatively, a composition ratio of "Rep_Comp" may be clearly distinguished in the compensation layer 480 and the electrode layer 490.

[0065] The Cath_Comp, which is the electrode material, may be SnO₂, ITO, IZO, IGZO and the like, but is not limited thereto. In addition, when at least two types of materials are used, in order to distinguish these, a sequential number may be added like Cath_Comp1, Cath_Comp2, Cath_Comp3 and the like.

[0066] The Rep_Comp, which is the compensation material, is combined with a conductive material and thus has a property of a high resistance. The Rep_Comp may be O₂, O₃, CO₂, CH₄, CH₄O, CCl₄, NO, N₂, H₂S and the like as an embodiment, but is not limited thereto. In addition, if two or more materials are used, in order to distinguish these, a sequential number may be added like Rep_Comp1, Rep_Comp2, Rep_Comp3 and the like.

[0067] In addition, when two or more materials are combined in a process such as a sputtering, corresponding materials may be written in parallel. For example, if Cath_Comp and Rep_Comp are two materials that are deposited in a process such as sputtering, the combination of Cath_Comp and Rep_Comp is indicated as Cath_Comp+Rep_Comp. When a composition ratio of each material is determined, the composition ratio may be written in parallel using a parenthesis like Cath_Comp (90%)+Rep_Comp (10%).

[0068] An example in which the compensation layer 480 and the electrode layer 490 are differentiated is described as a first embodiment of the present invention. The compensation layer 480 may include two or more different layers according to the distribution or the composition ratio of the compensation material.

[0069] FIGS. 7 to 10 are cross-sectional views of a display panel according to the first embodiment of the present invention. For the convenience of description, the EIL to first electrode 210 below the buffer layer 318 is not shown.

[0070] FIG. 7 illustrates a configuration 411 in which a compensation material is not included in the electrode layer 490a according to the first embodiment of the present invention, and a configuration 412 in which the composition ratios of the compensation material in the compensation layer and the electrode layer are different.

[0071] In FIG. 7, one Cath_Comp may be deposited during a sputtering method in a process of forming second electrodes 400a and 400b. The Cath_Comp and the Rep_Comp are sputtered, and compensation layers 480a and 480b are formed in a state in which the partial pressure ratio of the Rep_Comp is increased, and then the partial pressure ratio of the Rep_Comp is reduced. Alternatively, only the Cath_Comp may be sputtered to be deposited rather than sputtering the Rep_Comp. However, even in a case in which only the Cath_Comp is deposited to form the electrode layer 490a, the Rep_Comp may be included in the electrode layer 490b as shown by a reference numeral 412, due to a small amount of Rep_Comp maintained in a chamber. A reference numeral 411 illustrates a case in which a Rep_Comp, which is the compensation material, is not included in the electrode layer 490a.

[0072] As an embodiment of a reference numeral 412, when the Cath_Comp is IZO and Rep_Comp is O₂, a partial

pressure ratio of O₂ may be increased in order to form the compensation layer **480b** which is InZnOy. In addition, the electrode layer **490b** may be formed with InZnOx. Here, a relation of “x<y” is formed. The InZnOx forms a low resistance film and thus becomes the electrode layer since the partial pressure ratio of O₂ or O₃ is low in a sputtering process. The InZnOy forms a high resistance film and thus becomes the compensation layer since the partial pressure ratio of O₂ or O₃ is high in the sputtering process. The “x” may have a value of one to 2, and the “y” may have a value of two to three. Here, as an embodiment, after the compensation layer **480b** is formed in a state (e.g., 16%) in which a partial pressure of O₂ is increased in a ratio of Ar and O₂, the electrode layer **490b** is formed in a state (e.g., 9%) in which a partial pressure of O₂ is reduced in the ratio of Ar and O₂. Thus, a ratio (e.g., a %) of O₂ forming the compensation layer **480b** is higher than a ratio (e.g., B %) of O₂ forming the electrode layer **490b**.

[0073] The partial pressure means the ratio of the Rep_Comp among various gases in the chamber in the sputtering process, and this ratio is not absolutely equal to the composition ratio of the Rep_Comp in the compensation layer **480b**. However, since the higher the partial pressure ratio the higher the composition ratio of the Rep_Comp, the sputtering process may be performed such that the partial pressure ratio of the Rep_Comp in the compensation layer is higher than the partial pressure ratio of the Rep_Comp in the electrode layer.

[0074] FIG. 8 illustrates a configuration in which the compensation layer according to the first embodiment of the present invention is included, and here, the compensation layer includes two layers of which a composition ratio of Rep_Comp is different.

[0075] The Cath_Comp is deposited on the buffer **318**, the Rep_Comp is deposited in a regular partial pressure ratio. The first compensation layer **480c**, in which the Rep_Comp forms C %, is formed. The Rep_Comp is disposed on the first compensation layer **480c** in a reduced partial pressure ratio to form the second compensation layer **480d** in which the Rep_Comp forms D %. Next, the Rep_Comp is not sputtered and only the Cath_Comp is deposited.

[0076] In FIG. 8, the first compensation layer **480c** and the second compensation layer **480d** includes the same Rep_Comp, the partial pressure ratio is differentiated in a deposition process, the composition ratio of the Rep_Comp of the first compensation layer **480c** becomes C %, the composition ratio of the Rep_Comp of the second compensation layer **480d** becomes D %, and thus the first compensation layer **480c** and the second compensation layer **480d** have a relation of “C>D”.

[0077] FIG. 9 illustrates a configuration in which the compensation layer according to the first embodiment of the present invention includes three layers of which the composition ratio of the Rep_Comp are different. Identically to FIGS. 7 and 8, the Cath_Comp is deposited on the buffer **318**. A first compensation layer **480e** is formed by reducing the partial pressure ratio of Rep_Comp to three steps to deposit the Rep_Comp. A second compensation layer **480f** is formed by reducing the partial pressure ratio of the Rep_Comp and depositing the Rep_Comp on the first compensation layer **480e**. A third compensation layer **480g** is formed on the second compensation layer **480f** by reducing the partial pressure ratio of the Rep_Comp. Next, the Rep_Comp is not sputtered and only the Cath_Comp is deposited.

A process may progress such that the partial pressure ratio is reduced as the Rep_Comp is close to the electrode layer **490d**, and a relation of the composition ratios of the Rep_Comps in each compensation layer may have a relation of “E>F>G”.

[0078] Meanwhile, since the Rep_Comp may be left in the chamber although the Rep_Comp is not sputtered, a material forming the electrode layer **490d** may be Cath_Comp+Rep_Comp (P %). In this case, p may be smaller than G. As an embodiment, E, F, G and P may have a relation of “P<<G<F<E”.

[0079] Since different compensation materials form the second electrode **400** in various layers in FIGS. 7 to 9, a cathode-anode short due to a foreign body entered from the outside is prevented in the compensation layer **480** of the high resistance area where the compensation materials are contained plentifully, and thus the probability of a dark spot is blocked.

[0080] A showing of an interface between the compensation layer and the electrode layer or an interface between the compensation layers as a dotted line in FIGS. 4 to 9 is for showing that the composition ratio of the Rep_Comp which is the compensation material may be gradually changed at front and rear areas of these interfaces. A distribution of a compensation material at two interfaces **910** and **920** is described with reference to FIG. 10.

[0081] In FIG. 10, a Ref_Comp **1010** of a second compensation layer **480f** is formed of a very high density, that is F %. Meanwhile, a composition ratio of the Ref_Comp **1010** in a third compensation layer **480g** is G % which is lower than a composition ratio of the Ref_Comp **1010** in the second compensation layer **480f**. In addition, a composition ratio of the Ref_Comp **1010** in an electrode layer **490d** is P % which is a very low ratio. Here, the composition density of the Ref_Comp **1010** may be different based on the interfaces **910** and **920**, but the composition density may not be clearly distinguished and may be gradually reduced. This is because the composition ratio of the Ref_Comp may have an error due to the Ref_Comp left in the chamber even in a case in which the Ref_Comp is not deposited any more in the chamber performing the sputtering process. The present invention is applied to all embodiments such as an embodiment of a compensation material compensating a foreign body between an interface adjacent to a buffer layer and an interface far from the buffer layer based on two interfaces of the second electrode, for example a material forming a high resistance film is reduced gradually or in a step type.

[0082] FIGS. 11 to 13 are views illustrating a partial pressure ratio of a compensation material for forming the second electrode shown in FIGS. 7 to 9 and a composition ratio of the compensation material in the second electrode due to the partial pressure ratio.

[0083] A reference numeral **1101** of FIG. 11 is a partial pressure ratio of the Rep_Comp in a process of forming the second electrode **400b** equal to the reference numeral **412** of FIG. 7. A reference numeral **1102** illustrates a composition ratio of the Rep_Comp in the second electrode **400b** formed in a partial pressure ratio equal to that of the reference numeral **1101**. In the reference numeral **1102**, the composition ratio of the Rep_Comp is rapidly reduced at an interface between the compensation layer **480b** and the electrode layer **490b** in the second electrode **400b**. The compensation layer **480b** is formed between an interface making contact with the buffer layer **318** and an interface making contact

with the second electrode **490b**. After forming of the buffer layer **318**, a Cath_Comp material forming the second electrode **490b** is sputtered, and the Rep_Comp which is a material for forming the compensation layer **480b** may be sputtered in the sputtering process of the Cath_Comp material.

[0084] A reference numeral **1201** of FIG. **12** is a partial pressure ratio of the Rep_Comp during a process of forming the second electrode **400c** as shown in FIG. **8**. A reference numeral **1202** illustrates a composition ratio of the Rep_Comp in the second electrode **400c** formed in a partial pressure ratio equal to that of the reference numeral **1201**. In the reference numeral **1202**, the composition ratio of the Rep_Comp is rapidly reduced at an interface between the first compensation layer **480c** and the second compensation layer **480d**, and an interface between the second compensation layer **480d** and the electrode layer **490c** in the second electrode **400c**.

[0085] A reference numeral **1301** of FIG. **13** is a partial pressure ratio of the Rep_Comp during a process of forming the second electrode **400d** as shown in FIG. **9**. A reference numeral **1302** illustrates a composition ratio of the Rep_Comp in the second electrode **400d** formed in a partial pressure ratio equal to that of the reference numeral **1301**. In the reference numeral **1302**, the composition ratio of the Rep_Comp is rapidly reduced at an interface between the first compensation layer **480e** and the second compensation layer **480f**, and an interface between the second compensation layer **480f** and the electrode layer **490d** in the second electrode **400d**.

[0086] After the buffer layer **318** is formed, the Rep_Comp and the Cath_Comp are sputtered, the Rep_Comp is deposited by reducing the partial pressure ratio in stages as shown by the reference numeral **1301** to form the first, second, and third compensation layers **480e**, **480f**, and **480g**. Meanwhile, even though only the Cath_Comp is sputtered to form the electrode layer **490d**, the leftover Rep_Comp may be included in the electrode layer **490d**. Accordingly, a very small amount of, for example, P % of Rep_Comp may also be left in the second electrode **490d**.

[0087] The partial pressure ratio distributed in the compensation layer and the electrode layer corresponds to the reference numerals **1101**, **1201** and **1301** in FIGS. **11** to **13**. Thus, a distribution (or composition ratio) of the Rep_Comp which is a material forming the compensation layer is high in an area of the compensation layers **480b**, **480c**, **480d**, **480e**, **480f** and **480g**, and the distribution (or composition ratio) of the Rep_Comp is low in the electrode layers **490b**, **490c** and **490d**.

[0088] As described above, according to the present invention, since the compensation layer may not be separately formed and a material forming the compensation layer may be selectively input, a display panel and a display device capable of simplifying a process and capable of compensating a foreign body without an additional material or process and an investment of an equipment may be produced. In addition, a rate of defect in which a dark spot is generated due to a foreign body may be reduced by a foreign body compensation layer and thus quality of a display panel may be improved.

[0089] As a second embodiment of the present invention, an example in which the distribution or the composition ratio of the compensation material is gradually reduced in the compensation layer and the electrode layer is presented.

In the above-mentioned first embodiment, the partial pressure ratio of the Rep_Comp which is the compensation material is controlled in stages in the sputtering process. Therefore, in the second embodiment, an interface at which a composition ratio of a compound forming the compensation layer and the electrode layer has a rapid difference is not formed, and instead the Rep_Comp is gradually reduced. Thus, according to the second embodiment, the second electrode is formed rather than a separately distinguished compensation layer. The second electrode may be formed such that the composition ratio of the Rep_Comp is high at the interface close to the buffer layer and the composition ratio of the Rep_Comp is low at the opposite interface.

[0090] FIG. **14** is a cross-sectional view of a display panel according to the second embodiment of the present invention. For the convenience of description, the EIL to the first electrode **210** below the buffer layer **318** are not shown. In order to show the composition ratio or the distribution of the Rep_Comp, a molecule forming the Rep_Comp is shown as a reference numeral **1410**. In the second electrode **1490**, the composition ratio of the Rep_Comp **1410** is high in an area of an interface **1490a** making contact with the buffer layer **318**, and the composition ratio of the Rep_Comp **1410** is low in an area of an interface **1490b** spaced apart from and far from the buffer layer **318**. Therefore, a high resistance film is formed in the area close to the buffer layer **318** and thus a function of the compensation layer is provided to the area close to the buffer layer **318**, and a low resistance film is formed in the area far from the buffer layer **318**, and thus a function of the electrode layer is provided to the area far from the buffer layer **318**. Accordingly, an the electrical conductivity of an electrode increases in the low resistance film and a function for compensating a foreign body increases in the high resistance film. More specifically, the composition of the compensation material at the first interface **1490a** close to the organic light emitting layer is different from the composition of the compensation material at the second interface **1490b** which is opposite to the first interface **1490a**. As described with reference to FIG. **10**, a case in which the composition ratio of the compensation material **1010** is different in random interfaces **910** and **920** also reflects the embodiment of FIG. **14**.

[0091] FIGS. **15** to **17** are graphs illustrating the composition ratio of the Rep_Comp in the configuration of FIG. **14**. The composition ratio of the Rep_Comp between two interfaces **1490a** and **1490b** of the second electrode formed by gradually controlling the partial pressure ratio of the Rep_Comp in the sputtering is illustrated.

[0092] As a third embodiment of the present invention, the compensation layer may be formed using at least two types of Rep_Comp materials. For example, the compensation layer may be formed using Rep_Comp1 and Rep_Comp2 to increase a performance of a foreign body compensation. The Rep_Comp1 may be deposited together with the Cath_Comp to form the high resistance film. The Rep_Comp2 may be deposited together with the Cath_Comp to form the low resistance film of which a resistance is lower than that of the Rep_Comp1.

[0093] FIG. **18** is a cross-sectional view of a display panel according to the third embodiment of the present invention. A reference numeral **1801** is an embodiment in which two types of compensation materials form a second electrode **1800a** including two layers of compensation layers **1881** and **1882** and the electrode layer **490**. The Rep_Comp1 forms a

resistance film of which a resistance is higher than that of the Rep_Comp2. A reference numeral 1802 is an embodiment in which three types of compensation materials form a second electrode 1800b including three layers of compensation layers 1883, 1884 and 1885 and the electrode layer 490. The Rep_Comp3 forms a resistance film of which a resistance is higher than that of the Rep_Comp4. The Rep_Comp4 forms a resistance film of which a resistance is higher than that of the Rep_Comp5. As described above, the compensation material may be included in the electrode layer 490 in a very low ratio compared to the compensation layer.

[0094] FIG. 19 is a view illustrating a distribution of the compensation material of the second electrode and the compensation layer including two types of materials according to the third embodiment of the present invention. The Rep_Comp1 forming the first compensation layer 1881 of the reference numeral 1801 of FIG. 18 is marked as a reference numeral 1910, and the Rep_Comp2 forming the second compensation layer 1882 of the reference numeral 1801 of FIG. 18 is marked as a reference numeral 1920. The first compensation layer 1881 forms a high resistance film. The second compensation layer 1882 forms a resistance film of which a resistance is lower than that of the high resistance film. The electrode layer 490 forms a low resistance film of which a resistance is lower than that of the resistance film formed by the second compensation layer 1882. A small amount of Rep_Comp2 may be included in the electrode layer 490. The high resistance film is formed in the area close to the buffer layer 318 and thus a function of the compensation layer is provided to the area close to the buffer layer 318, and the low resistance film is formed in the area far from the buffer layer 318, and thus a function of the electrode layer is provided to the area far from the buffer layer 318. Accordingly, the electrical conductivity of an electrode is increased in the low resistance film and a function for compensating a foreign body is increased in the high resistance film. More specifically, the composition of the compensation material in the first compensation layer 1881 at the first interface close to the organic light emitting layer is different from the composition of the compensation material in the second compensation layer 1882 at the second interface which is opposite to the first interface.

[0095] FIG. 20 is a chart illustrating a relation between the Cath_Comp which is a material forming the second electrode and the Rep_Comp which is a material sputtered to form the compensation layer. As shown in FIG. 20, the Rep_Comp that is the material forming the compensation layer may be variously selected and formed according to the Cath_Comp forming the second electrode. In addition, two or more Rep_Comps may be selected to form the compensation layer, and this is described with reference to FIGS. 18 and 19. In this case, after the material of the Rep_Comp1 which forms the high resistance film of which the resistance is comparatively high is deposited adjacently to the buffer layer, the material of the Rep_Comp2 having a resistance lower than that of the Rep_Comp1 may be deposited on the Rep_Comp1.

[0096] In addition, since a relation chart facilitating the forming of the compensation layer is formed even in a relation between the Cath_Comp that is the electrode material and the Rep_Comp that is the compensation material as shown in FIG. 20, a compensation material which may be

more easily deposited according to a selection of a specific electrode material or of which a compensation function is excellent may be selected.

[0097] FIG. 21 is a chart illustrating an increase of a sheet resistance according to the partial pressure ratio of the Rep_Comp according to an embodiment of the present invention. If the partial pressure ratio increases when the Rep_Comp is O₂, an amount of O₂ included in the compensation layer of the second electrode increases. In addition, the sheet resistance increases according to the increase of O₂. Meanwhile, a deviation according to the thickness is not high.

[0098] FIG. 22 is a view illustrating a comparison between the existing panel and a panel in which the foreign body compensation layer proposed in the present invention is included. In FIG. 22, a reference numeral 2210 indicates a penetrated foreign body in a panel process. In a reference numeral 2201, when a foreign body 2210 penetrates into the second electrode 290 in which a compensation layer is not included, a short between the first electrode 210 and the second electrode 290 is generated. In contrast, as shown by a reference numeral 2202, even though a foreign body 2210 penetrates into the second electrode 400 including the compensation layer 480 and the electrode layer 490, a short between the first electrode 210 and the second electrode 490 is not generated by the compensation layer 480. Thus, defect such as a dark spot is not generated.

[0099] Table 1 is a table illustrating a foreign body compensation performance according to the present invention.

TABLE 1

Substrate	The number of dark spots	The number of dark spots generated due to the foreign body
Ref. 1	239	177
Ref. 2	245	211
Ref. 3	243	156
Include a foreign body compensation layer	125	93

[0100] As disclosed in table 1, in Ref.1, Ref.2 and Ref.3 to which the present invention is not applied, an average of the number of the generated dark spots is 242.3, and among these, the number of the dark spots due to the foreign body is 181.3. However, according to the present invention, all of the number of the generated dark spots is 125, and the number of the dark spots due to the foreign body is 93. Thus, the present invention has an effect in which the number of the dark spots is reduced by a half or more.

[0101] An embodiment of the present invention provides a structure including the compensation layer preventing a short between electrodes due to a foreign body in a display panel. Specially, the foreign body compensation layer forming the high resistance film is formed in a process of depositing Transparent Conductive Oxide (TCO) such as IZO, ITO and IGZO as the second electrode. The second electrode and the foreign body compensation layer are formed in one chamber without an additional process or an additional equipment by reducing a distribution of the compensation material (i.e., the Rep_Comp) which functions as the foreign body compensation layer. Oxide film which may become a transparent cathode of an OLED, such as WO and Mo besides TCO may be applied to the second

electrode, and the present invention is not limited to a specific material of the second electrode.

[0102] According to the present invention, since the high resistance film may be formed without an additional process when a foreign body or a bump exists on an electrode, a short between the first electrode (e.g., anode) and the second electrode (e.g., cathode) is prevented. Thus, the probability of dark spot generation is reduced and a panel yield is increased. In the present specification, the second electrode and the high resistance film may be formed in the same process or at the same time, by controlling a distribution ratio of the compensation material forming the high resistance film in a process of forming the second electrode which is transparent. The above-mentioned controlling of the distribution ratio of the compensation material may include a method of gradually reducing the distribution ratio of the compensation material, a method of forming the distribution of the compensation material discretely such that the foreign body compensation layer is clearly distinguished from the second electrode, and the like. In addition, the high resistance film of the foreign body compensation layer, a resistance film having about medium resistance, and the second electrode may be formed using two or more foreign body compensation materials.

[0103] When the second electrode is sputtered on a panel, since the compensation material is partially pressed and is deposited on the panel according to a predetermined partial pressure ratio before the compensation material is sputtered in the second electrode or in a process of the sputtering, a foreign body compensation structure may be included in the panel without additional and separate process and equipment.

[0104] The above description and the accompanying drawings provide an example of the technical idea of the present invention for illustrative purposes only. Those having ordinary knowledge in the technical field, to which the present invention pertains, will appreciate that various modifications and changes in form, such as combination, separation, substitution, and change of a configuration, are possible without departing from the essential features of the present invention. Accordingly, the embodiments disclosed in the present invention are merely to not limit but describe the technical spirit of the present invention. Further, the scope of the technical spirit of the present invention is limited by the embodiments. The scope of the present invention shall be construed on the basis of the accompanying claims in such a manner that all of the technical ideas included within the scope equivalent to the claims belong to the present invention.

1. An organic light emitting display device comprising:
a substrate;
a first electrode on the substrate;
an organic light emitting layer on the first electrode; and
a second electrode on the organic light emitting layer, the second electrode including at least a first layer and a second layer on the first layer, the first layer and the second layer having differing composition of compensation materials that increase electrical resistance of the second electrode, wherein a portion of the second layer extends toward the first electrode, and a portion of the first layer extends further toward the first electrode than the portion of the second layer.

2. The organic light emitting display device of claim 1, wherein the first layer and the second layer are sequentially positioned from the organic light emitting layer, and
a composition ratio of the compensation material included in the first layer is larger than that of the compensation material included in the second layer.

3. The organic light emitting display device of claim 1, wherein the organic light emitting layer comprises:
a first light emitting layer on the first electrode;
a transport layer on the first light emitting layer; and
a second light emitting layer on the transport layer, and light emitted from the first and second light emitting layers combined with each other corresponds to white light.

4. An organic light emitting display device comprising:
a substrate;
a first electrode on the substrate;
an organic light emitting layer on the first electrode; and
a second electrode on the organic light emitting layer, the second electrode comprising a first compensation layer, a second compensation layer, and an electrode layer sequentially from the organic light emitting layer, wherein the first compensation layer and the second compensation layer have differing composition of compensation materials that increase electrical resistance of the second electrode, and
wherein a first compensation material in the first compensation layer and a second compensation material in the second compensation layer are different.

5. The organic light emitting display device of claim 1, wherein the compensation material is any of O₂, O₃, CO₂, CH₄, CH₄O, CCl₄, NO, N₂, or H₂S.

6. An organic light emitting display device comprising:
a substrate;
a first electrode on the substrate;
an organic light emitting layer on the first electrode; and
a second electrode of which compositions of a compensation material that increases electrical resistance of the second electrode are different at a first interface close to the organic light emitting layer and at an upper surface of the second electrode, wherein the upper surface of the second electrode extends toward the first electrode, and the first interface extends further toward the first electrode than the upper surface of the second electrode.

7. The organic light emitting display device of claim 6, wherein a composition ratio of the compensation material in the second electrode is highest at the first interface and the composition ratio of the compensation material in the second electrode is lowest at the upper surface of the second electrode.

8. An organic light emitting display device comprising:
a substrate;
a first electrode on the substrate;
an organic light emitting layer on the first electrode; and
a second electrode of which compositions of compensation materials that increase electrical resistance of the second electrode are different at a first interface close to the organic light emitting layer and at a second interface farther from the organic light emitting layer than the first interface,
wherein the compensation materials comprise a first compensation material and a second compensation material, a composition ratio of the first compensation

material is highest at the first interface, a composition ratio of the second compensation material is highest at an area between the first interface and the second interface, and a composition ratio of the first compensation material and the second compensation material is lowest at the second interface.

9. The organic light emitting display device of claim 6, wherein an electrode material forming the second electrode is SnO_2 , and the compensation material is one of O_2 , O_3 , CO_2 , and CH_4 .

10. An organic light emitting display device comprising:
a substrate;

a first electrode on the substrate;

an organic light emitting layer on the first electrode; and

a second electrode of which compositions of a compensation material that increase electrical resistance of the second electrode are different at a first interface close to the organic light emitting layer and at a second interface farther from the organic light emitting layer than the first interface,

wherein an electrode material forming the second electrode is ITO and the compensation material is one of CH_4O , CCl_4 , and NO .

11. The organic light emitting display device of claim 6, wherein an electrode material forming the second electrode is IZO and the compensation material is one of O_2 , O_3 , N_2 , and H_2S .

* * * * *

专利名称(译)	有机发光显示装置		
公开(公告)号	US20160315281A1	公开(公告)日	2016-10-27
申请号	US14/866653	申请日	2015-09-25
[标]申请(专利权)人(译)	乐金显示有限公司		
申请(专利权)人(译)	LG DISPLAY CO. , LTD.		
当前申请(专利权)人(译)	LG DISPLAY CO. , LTD.		
[标]发明人	HEO JOONYOUNG KIM YOUNGMI PARK YONGMIN JEONG YOONSEOB		
发明人	HEO, JOONYOUNG KIM, YOUNGMI PARK, YONGMIN JEONG, YOONSEOB		
IPC分类号	H01L51/52 H01L51/50		
CPC分类号	H01L51/5234 H01L51/504 H01L51/5092 H01L51/5072 H01L51/5221 H01L51/5056 H01L2251/308 H01L2251/301 H01L51/5088 H01L2251/306 H01L2251/5346		
优先权	1020150057471 2015-04-23 KR		
其他公开文献	US9502677		
外部链接	Espacenet USPTO		

摘要(译)

一种具有用于钟表的外摆线火车的分秒装置。该装置包括一个分秒式小齿轮, 它带有一个回程针并安装成可围绕该计时器的一个旋转心轴自由旋转; 差速器, 其具有适于运动学地连接到所述钟表的电源的进入轮; 第一出口轮, 其通过行星轮运动学地连接到所述进入轮并与所述分针齿轮啮合; 第二出口轮, 其通过所述行星轮运动学地连接到所述进入轮; 以及控制杆, 允许阻挡第一出口轮或第二出口轮, 使得通过控制杆释放第一和第二出口轮中的任何一个都适于由入口轮驱动, 当入口轮运动学地连接到手表的电源, 从而允许阻止或分别释放飞返手。

